

Service Doors

Installation Manual
for use in GB, FR, DE, ES,
IT, SI, SE, AT, CH, IE, LU

EN

Original Installation Manual

Contents

1	Introduction.....	2
2	Symbols.....	3
3	Regulations and standards.....	3
4	Installation audit form.....	3
5	Serviceability.....	3
6	Drawings and models.....	4
7	Model overview.....	4
8	Packaging.....	5
9	Tools required.....	5
10	Parts and position.....	6
11	Installation steps.....	7
12	After installation.....	12
13	Servicing.....	12
14	Questions / customer service.....	13

1. Introduction

This is the installation manual for the Thetford service doors. The manual is meant for qualified installers who will install the service doors in a mobile leisure vehicle. Read the information and instructions carefully and follow them strictly to install the service doors safely and correctly.

Also read the warnings in the user manual before testing the service doors after installation.

This document is version 200262/1121-V05 of the installation manual. Please visit www.thetford.com for the most recent version.



If the appliance is not installed in accordance with national and European regulations, rules and standards this will void the warranty.

2. Symbols

Key to symbols:



Warning. Risk of injury and/or damage.



Attention. Important information.



Note. Additional information.

3. Regulations and standards



Do not modify this appliance, unless the modification is authorised and carried out by the manufacturer or their agent.



Use only genuine and approved parts and materials.



Wear the correct Personal Protective Equipment during the installation. Also follow the applicable safety regulations.

4. Installation audit form

Thetford offers an additional service by auditing the installation of its products. This means that when a Thetford product is installed a Thetford local service representative will carry out a specific audit based on the Thetford installation instructions. The audit is meant as a reference for the specific model to ensure correct installation. In any case the Thetford local service representative can be contacted for any additional support related to the installation of the product.

5. Serviceability

The installer of Thetford products is responsible for proper installation to ensure the correct functionality and serviceability of the appliance. In terms of serviceability, this means that a dealer or an authorised Thetford service partner must be able to remove and re-install the Thetford products within the time that is allowed according to the Thetford time-list, using standard tools and equipment.

This is to claim any warranty during the period of 3 years after purchase date. The serviceability of the product is also included in the audit. In case of any queries on this subject, please contact the Thetford local service representative before installing the product.

6. Drawings and models

Table 1: Available drawings and models

Model	Door type	Cut-out drawing	Mounting plate drawing	3D model (simplified)
Door 3	D3	LE806	N/A	LE806
Door 3 with rain diverter	D3	LE807	N/A	LE807
Door 4	D4	LE808	LE566	LE808
Door 5	D5	LE809	LE497	LE809
Door 6	D6	LE810	LE715	LE810
Door 7	D7	LE181	LE803	LE181

7. Model overview

Table 2: Overview of available Thetford service doors models

Model	Door type	Dimensions HxW (mm)	Daylight opening	Cut-out dimensions HxW (mm)	Rain diverter	Net weight (kg)
Door 3	D3	385 x 335	330 x 280	349 x 296	No	1.0
Door 3 with rain diverter	D3	340 x 385	280 x 330	296 x 349	Yes	1.0
Door 4	D4	395 x 700	330 x 630	348 x 648	Yes (3 sides)	1.4
Door 5	D5	340 x 785	280 x 730	297 x 749	Yes	1.5
Door 6	D6	465 x 1038	400 x 980	419 x 997	Yes	2.5
Door 7	D7	346 x 1108	282 x 1051	299 x 1069	Yes	2.3



For more detailed information Product Information Sheets per model are available upon request.

8. Packaging

Table 3: Packaging

Door type	Pallet packaging Amount on pallet	5-pack packaging
D3	90	Available
D4	45	Available
D5	45	Available
D6	30	-
D7	30	-



Door inner is not supplied with the 5-pack. Please order separately.



The maximum stack height is 3 pallets high for pallet packaging and 1 pallet high for 5-pack packaging.



The pallet size depends on the door type.

9. Tools required

- Tool for sealant
- Pressure fixture or hammer
- Screwdriver

10. Parts and position

Service door parts

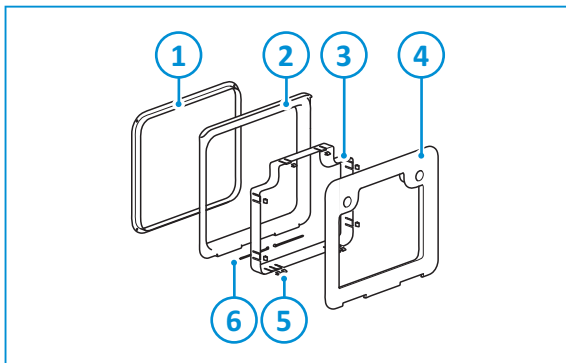

1. Frame inner
2. Frame outer
3. Door inner
4. Door outer
5. Door clips
6. Hinge pins



The parts for every door type are similar, only the measurements are different. Therefore only the parts for D3 are depicted.

General position:

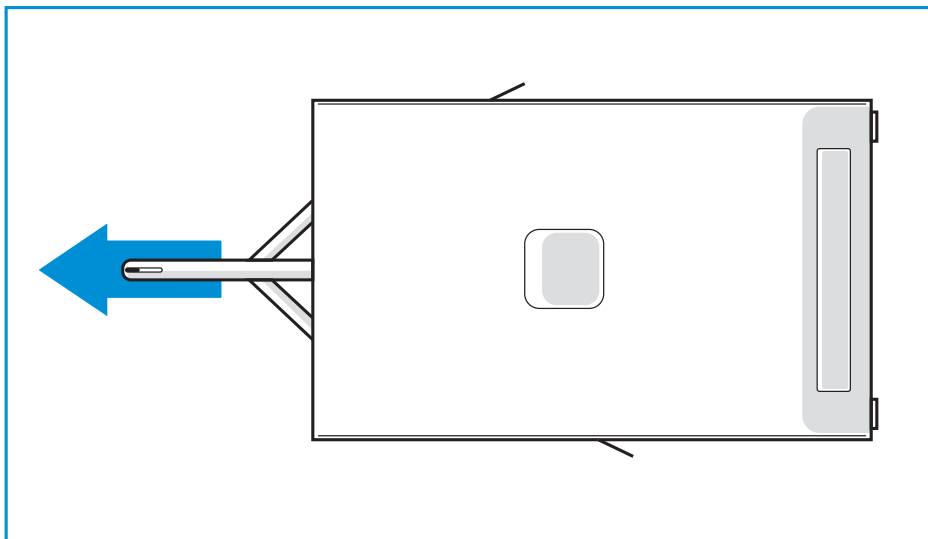

Install the service door only in one of the side walls or the back wall of a vehicle. This design is not suitable for a roof or floor or front installation.



Install the service door in any direction, but preferably with the hinges to the top, downwards or in the driving direction.



Only for D3: The frame outer [3] for D3 is available with or without 'rain diverter'. If the hinges are placed downwards Thetford recommends to install a frame outer with rain diverter.

Position cut-out vehicle wall:

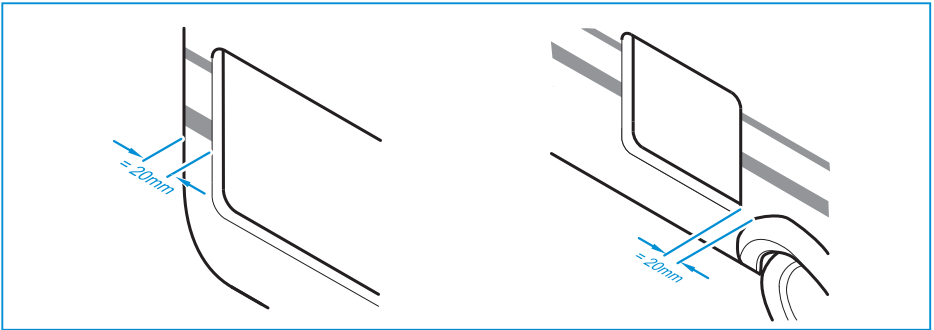

Install the service door only in a flat wall of the vehicle.



Check the minimum available space for the service door (see image).



If the wall of the vehicle is not prepared, Thetford advises to strengthen the cut-out wall, for example with an aluminium frame. It secures the screws of the door.



The wall thickness needs to be between 23mm and 39mm. Contact Thetford if the vehicle wall thickness is outside this range.

11. Installation steps

- Make the mounting plate.



See Drawings and models for references to the drawings of the mounting plate dimensions.

- Make the cut-out for the service door and the door panel. See Parts and position for information about cut-outs.



Make sure that the decorative stripes on the door panel are in line with those on the vehicle [see image].

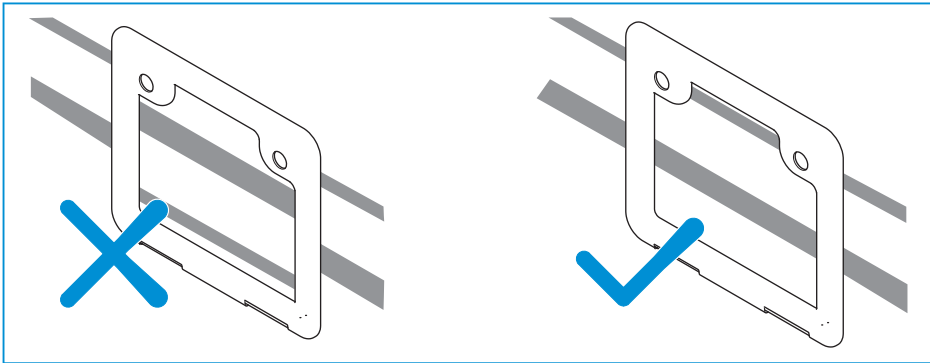

See Drawings and models for references to the drawings of the cut-out dimensions.

- Remove all hinge pins [6] from the service door.



The amount of hinge pins is dependent on the type of door.

- Remove the door outer [4] from the frame outer [2].



Thetford advises to install the frame outer without the door for the best installation. If this is not possible, install the frame outer with no extra stress load of the door (e.g. by keeping the door horizontal while installing).

- Put the door outer [4] on a flat table.
- Fill the groove of the door outer [4] with sealant.



For water-tight bonding, always follow the instructions of your bonding manufacturer.

- Put the door panel in the door outer [4].

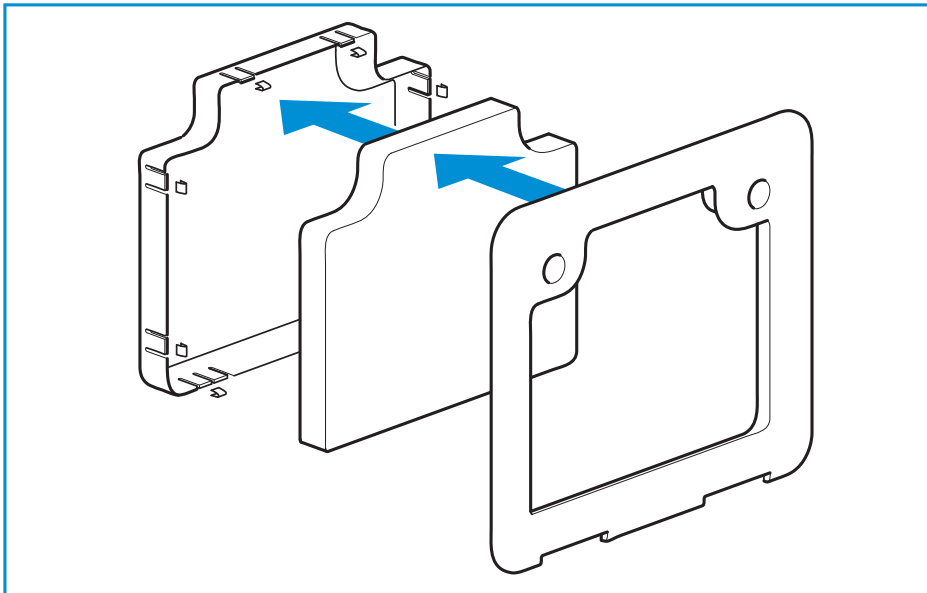

Use the cut-out from the vehicle's wall as the door panel. The door panel fits between the door outer [4] and the door inner [3]. Door clips [5] are necessary to create a permanent connection between the door outer [4] and the door inner [3].



Door clips are supplied by Thetford. The amount of door clips is dependent on the type of service door. With pallet packaging, door clips have been pre-installed on the door inner. With 5-pack packaging, the door clips are supplied separately.

- Hammer the door clips [5] on the indicated positions of the door inner [3] (if applicable).
- Hammer the door inner [3] on the door outer [4].
- Put the frame outer [2] on a flat table.
- Fill the groove of the frame outer [2] with sealant.



For water-tight bonding, always follow the instructions of your bonding manufacturer.

- Place the frame outer [2] in the opening of the outside wall.



The following step does not apply to service door 3.

- Place the mounting plate in the middle of the frame outer [2].

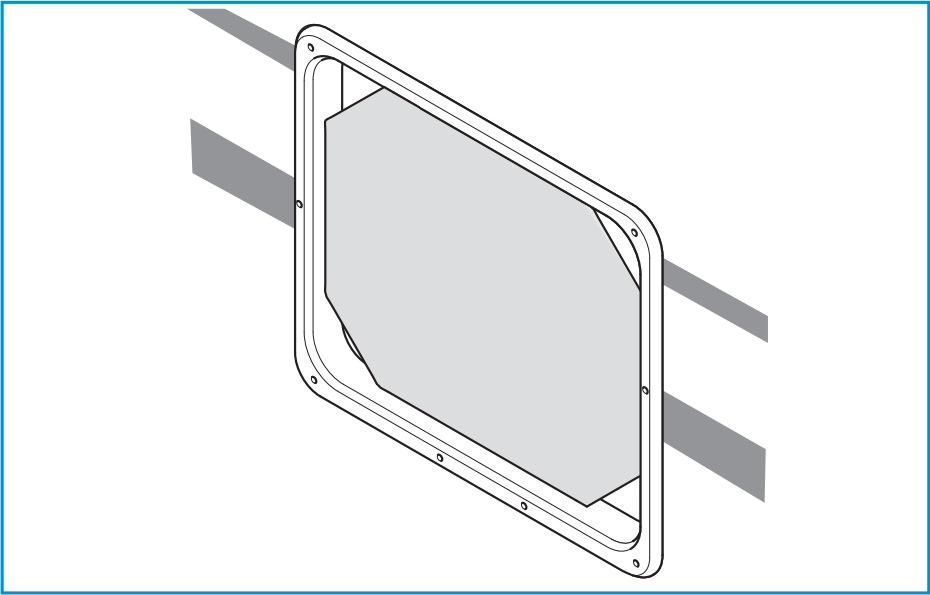

The mounting plate ensures the correct built-in of the frame outer [2].

- Screw the frame outer [2] on the outside wall. Start in the upper corners, then fasten the screws in the lower corners.

- Fasten all screws step by step from the middle to the corners. End with the screws on the smallest side.

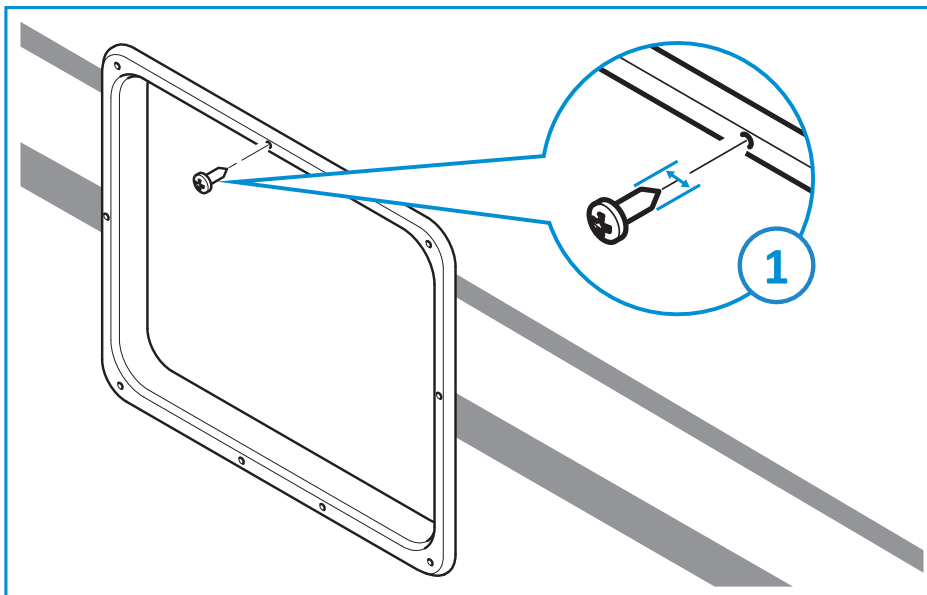

1: Maximum screw diameter = 4.2mm



Screws are not supplied by Thetford. The type and length are dependent on the wall and the installation construction.



Fasten all screws one more time when the sealant is almost cured. The time at which this needs to be done and the required torque depend on the type of sealant.

- Remove the mounting plate.
- Place the door to the frame outer [2].
- Put the hinge pins [6] back in position.
- Close the door.
- If applicable, place the cylinder.
- Remove all sealant around the frame outer [2] and door.
- Clean the door and the outside wall.

If applicable:

- Place the frame inner [1] on the inside wall.
- Screw the frame inner [1] onto the inside wall.

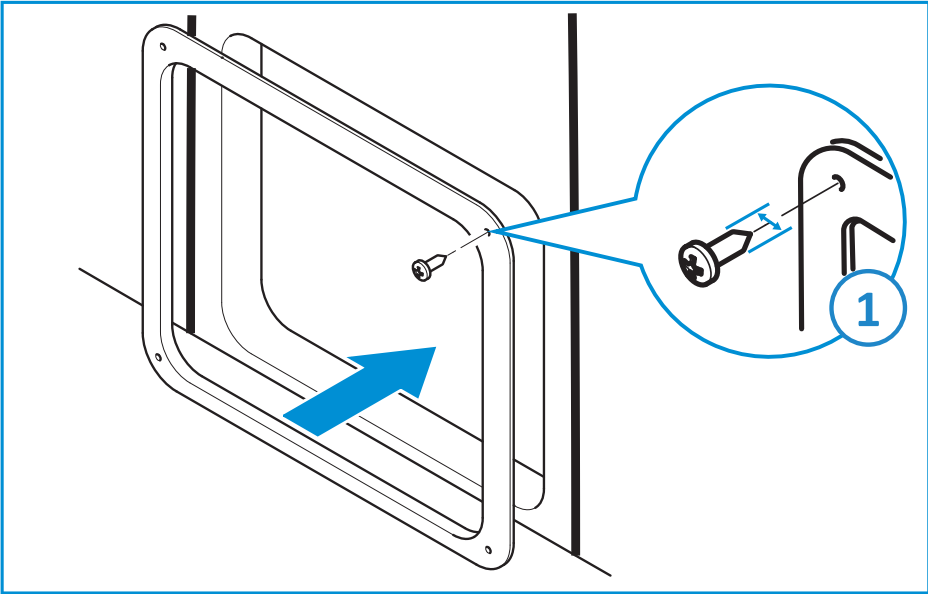

1. Maximum screw diameter = 4.2mm



The frame inner is a cosmetic part of the construction. It covers sharp edges and provides a neat finish.



Screws are not supplied by Thetford. The type and length are dependent on the wall and the installation construction.



Only for D3: The frame inner for service door 3 is available in several variants. Information is available upon request.

12. After installation

- Ensure that all packaging materials have been removed.
- Check if all buttons and locks function correctly.
- Check if the door can be closed correctly.

13. Servicing

All servicing must be carried out by an approved competent person.

For service, please contact your authorised local Service Centre giving details of the model and serial number on the data badge plus date of purchase.

The data badge can be found on the inside of the service door.



14. Questions / customer service

- Visit www.thetford.com.
- Contact Customer Service Thetford in your country. See the addresses on the back.

EUROPEAN HEADQUARTERS

Thetford B.V.
Nijverheidsweg 29
P.O. Box 169
4870 AD Etten-Leur
The Netherlands

T +31 76 504 22 00
F +31 76 504 23 00
E info@thetford.eu

UNITED KINGDOM

Thetford Ltd.
Unit 6
Brookfields Way
Manvers, Rotherham
S63 5DL, England
United Kingdom

T +44 844 997 1960
F +44 844 997 1961
E info@thetford.eu

GERMANY

Thetford GmbH
Schallbruch 14
D-42781 Haan
Deutschland

T +49 2129 94250
F +49 2129 942525
E info@thetford.eu

FRANCE

Thetford S.A.R.L.
Parc BUROPLUS / Bâtiment 6
18, Boulevard de la Paix
95800 CERGY
France

T +33 1 30 37 58 23
F +33 1 30 37 97 67
E info@thetford.eu

ITALY

Thetford Italy c/o Tecma s.r.l.
Via Flaminia
Loc. Castel delle Formiche
05030 Otricoli (TR)
Italia

T +39 0744 709071
F +39 0744 719833
E info@thetford.eu

SPAIN AND PORTUGAL

Mercè Grau Solà
Agente para España y Portugal
c/ Castellet, 36 bxs 2ª
08800 Vilanova i la Geltrú
Barcelona
España

T +34 938 154 389
F not available
E info@thetford.eu

SCANDINAVIA

Thetford B.V.
Representative Office Scandinavia
Hantverkaregatan 32D
521 61 Stenstorp
Sverige

T +46 31 336 35 80
F +46 31 44 85 70
E info@thetford.eu

AUSTRALIA

Thetford Australia Pty. Ltd.
130-132 Freight Drive
Somerton, VIC 3062
Australia

T +61 3 9358 0700
E infoaus@thetford.com.au
www.thetford.com.au

CHINA

Thetford China
Rm. 1207, Coastal Building
(East Block)
Haide 3rd Road, Nanshan District
Shenzhen, 518054
China

T +86 755 8627 1393
F +86 755 8627 1673
E info@thetford.cn
www.thetford.cn